

THE ULTIMATE PHASE-TOOL—
PUTS YOU IN PHASE WHEN THE POLARITY BUTTON WON'T



IBP / IBP Junior

- Continuously variable natural analog phase adjust.
- Allows mics to be placed where they sound best individually.
Compromising mic placement problems due to phase problems is not necessary when using IBP.
- Line level balanced XLR in and out.
- Rack mountable, 4 units fit in a 1U space.
- Real time all analog phase sweep between 0° and 180°
- Audiophile quality sound and construction.

IBP (Includes the above features plus all the following:)

- Internal super quality active direct box.
- Internal “re-amplifier” to convert pro-level to guitar level, which can be used with or without phase adjust.
- Buffered instrument level output for driving long guitar cables.
- Allows splitting between two instrument amps with transformer isolation and phase sweep.

The IBP and IBP Junior easily eliminate the undesirable hollow sound when combining out-of-phase and partially out-of-phase audio signals. Designed as a phase problem solving device, the IBP Analog Phase Alignment Tool has quickly become popular among audio engineers as not only a “fix it” tool but as a controlling audio phase creative, tonal color tool.

Little Labs IBP / IBP Jr: THE ORIGINAL PHASE TOOL

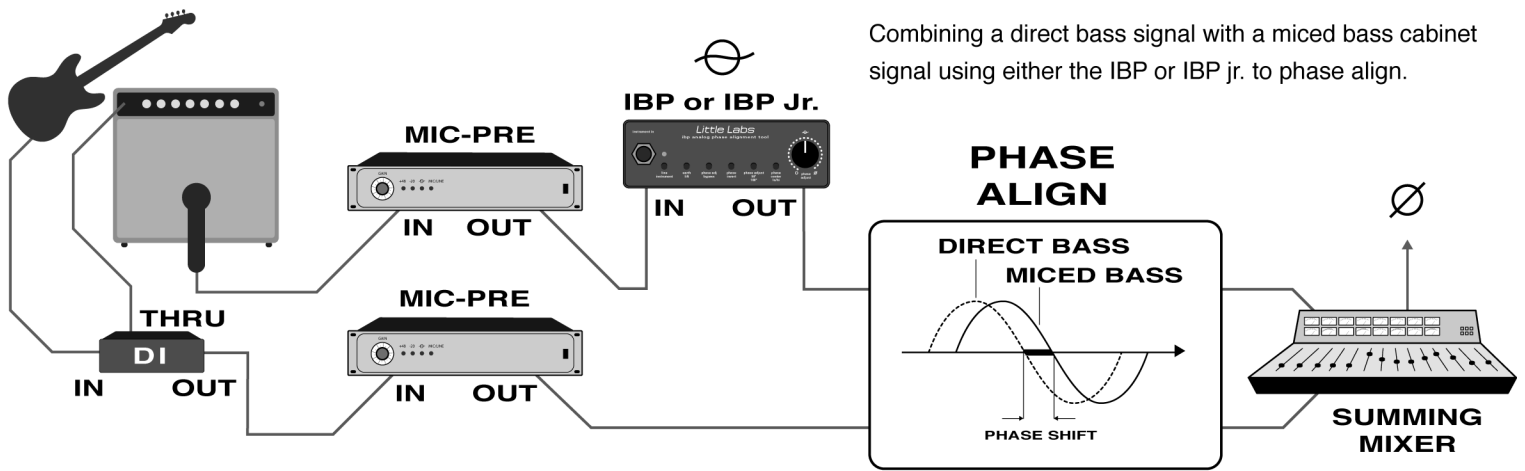

Combining a miced bass cabinet signal with a direct Bass signal using the IBP as a direct box and to phase align.

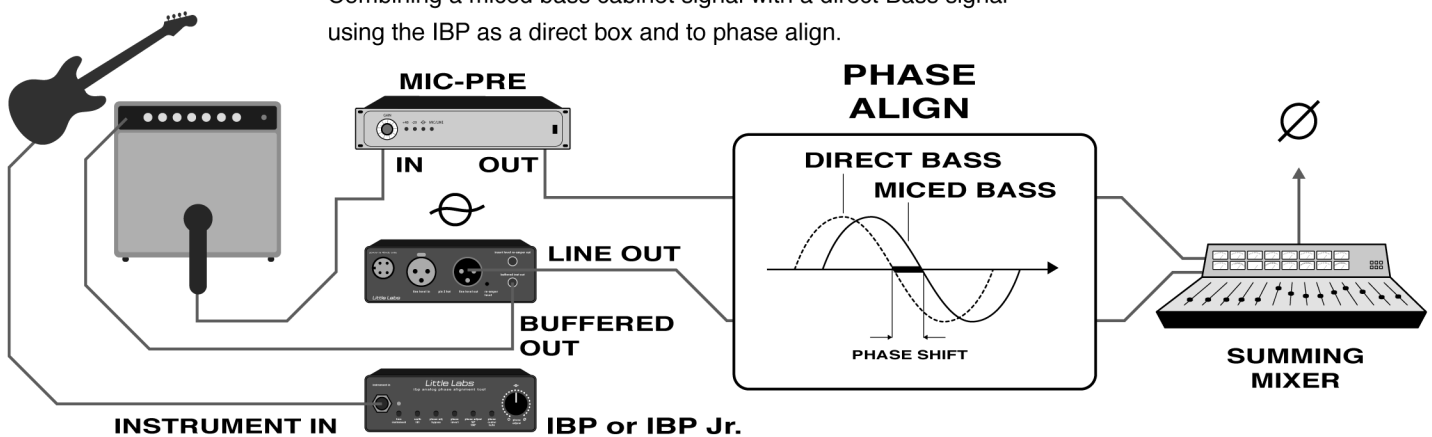

Combining inside and outside kick drum mics using the IBP or IBP jr. to phase align.

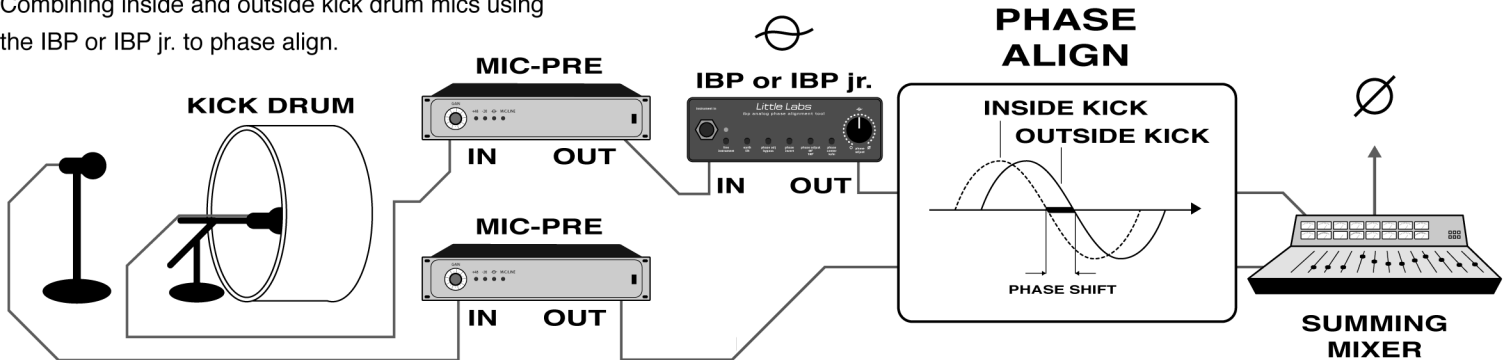

Combining top and bottom snare drum mics using the IBP or IBP jr. to phase align.

